

MYCALEX INSULATORS



CRYPEX COMPOSITES LLC
 Mykroy/Mycalex® Ceramics
 125 Clifton Boulevard, Clifton NJ. 07011
 Phone:+1- 973-779-8866 Fax: +1-973-779-2013
www.mycalexinsulators.com



MM50XC60-110

MYCALEX® stand-off insulator



MM50XC60-110

Manufacturing process : TRANSFER MOLDING

MATERIAL: Glass-Mica Ceramic Grade MM451

Operating Temperature -50 to 450°C

ROHS compliant (Pb Free)

Mycalex Insulators are made from inorganic materials that do not burn , glass, mica and metal inserts. Compliant to EN45545-2, NF F16-101 and NF F16-102

CTI - >600

Insert : Nickel Plated Carbon Steel. Brass or Stainless Steel available on request.



Metric Threads

Part	Thread Pitch (mm)	Thread Dia. (inch)	Pitch mm	Weight (kg)
MM50XC60-110- M10	2F	M 10	1.5	0.3
MM50XC60-110 -M12	2F	M 12	1.75	0.3

Inch Threads

Part	Thread Pitch (mm)	Thread Dia. (inch)	Pitch Threads /Inch	Weight (kg)
MM50XC60-110-0375 3/8 -16 UNC	2F	3/8"	16	0.3
MM50XC60-110-0437 7/16-14 UNC	2F	7/16"	14	0.3
MM50XC60110-0500 1/2 -13 UNC	2F	1/2"	13	0.3

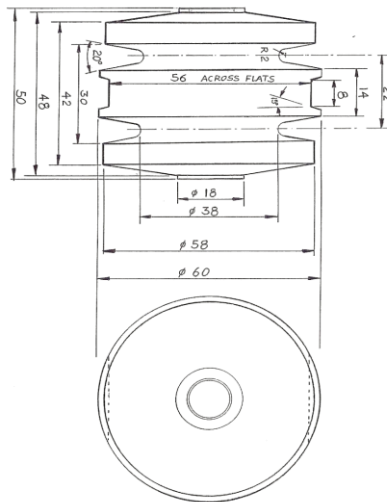

Dimensional Values	
Height	50mm ± 0.25
Diameter	60mm
Hexagonal across the flats	56 mm
Creepage distance	110 mm
Mechanical Characteristics	
Tensile Strength	≥1,500 daN
End flexural strength	500 daN
Compressive strength	7000 daN
Torsion (female insert)	>90 N-m
Electrical Characteristics	
Arc over voltage in air	>26 kV
Breakdown voltage (dry)	>26 kV
Insulation resistance G-Ohm at 1,000V DC	≥200 GΩ
Capacitance (1KHz)	6.2 pF
Test Conditions	
Voltage	22 kV
Frequency	60Hz
Duration	1 min



Made with pride in the USA

To the best of our knowledge the information contained herein is accurate; however, Crystex Composites LLC does not accept any liability regarding the accuracy or completeness of such information. Purchaser has the sole responsibility in determining the suitability of any material described herein for the use contemplated and the processing of such material by purchaser

MYCALEX INSULATORS